













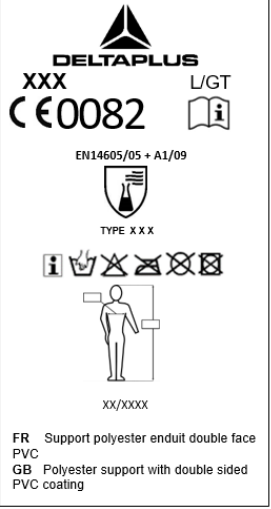
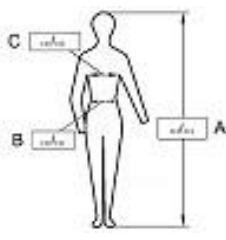



<p>① →</p> <p>② →</p> <p>⑦ →</p> <p>⑤ →</p> <p>⑥ →</p>  <p>← ③</p> <p>← ④</p> <p>← ③</p> <p>← ⑨</p> <p>← ⑧</p> <p>FR Support polyester enduit double face PVC GB Polyester support with double sided PVC coating</p>	<p>(3)</p>  <p>A STATURE / HEIGHT INTERVALS B TOUR DE TAILLE / WAIST ROUND C TOUR DE POITRINE / CHEST ROUND</p>	<p>① →</p> <p>② →</p> <p>⑦ →</p> <p>⑤ →</p> <p>⑥ →</p>  <p>← ③</p> <p>← ④</p> <p>← ③</p> <p>← ⑨</p> <p>← ⑧</p> <p>FR Support polyester enduit double face PVC GB Polyester support with double sided PVC coating</p>	<p>TR: İtihatçı firma : Delta Plus Personel Giyim ve İş Güvenliği Ekipmanları San. ve Tic. Ltd. Şti. Çobançeşme Mahallesi, Sanayi Caddesi No:58/A-B, Yenibosna, Bahçelievler/ İstanbul - Türkiye.</p> <p>Tel : +90 212 503 39 94</p> <p>RU:  TP TC 019/2011</p> <p>UA: </p>
---	--	---	---